

SINGLE UNIT INSTALLATION INSTRUCTIONS

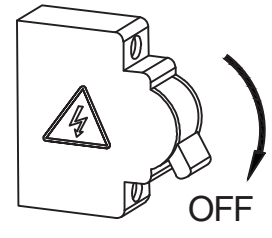

STEP 1: Switch OFF the power before starting the installation.

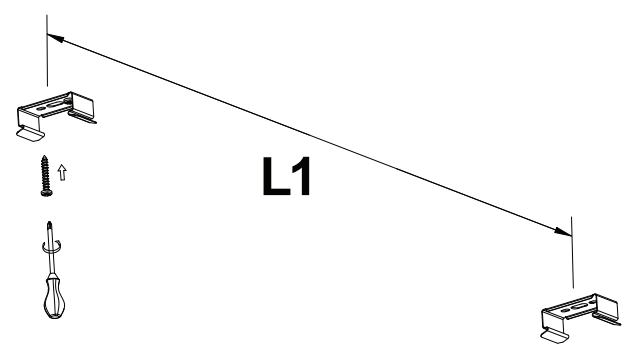

STEP 2: Fix the mounting brackets onto the ceiling using screws and expansion plug (included). Please refer to table 1 for installing the mounting bracket distance points.

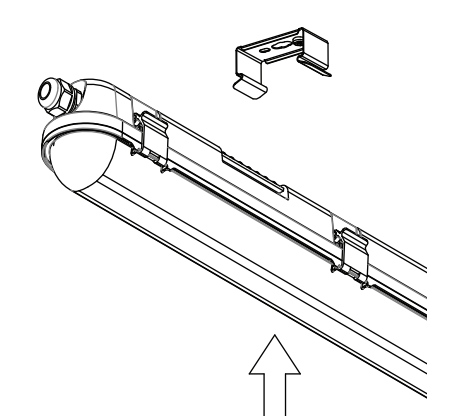

STEP 3: Mount waterproof lamp onto the mounting brackets.

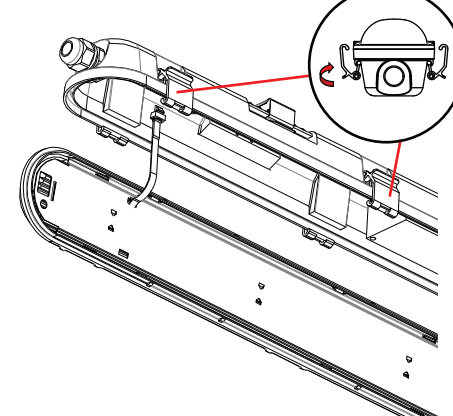

STEP 4: Open the side clips of waterproof fitting and open the diffuser as shown in the diagram.

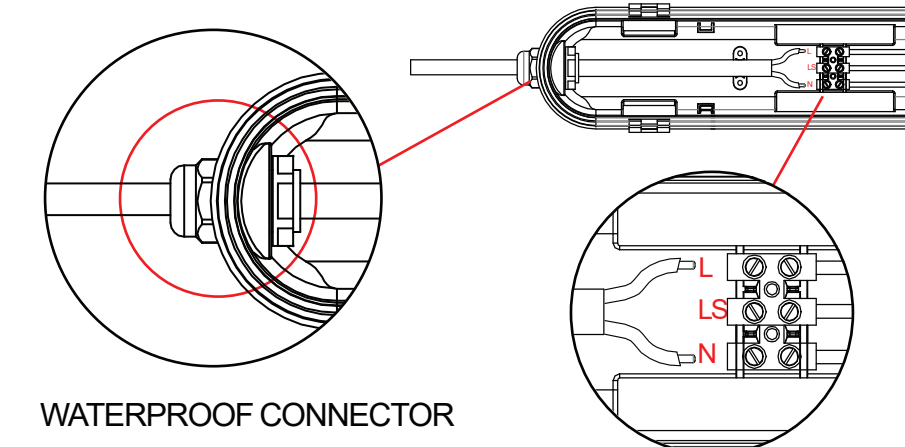

STEP 5: Fasten the waterproof connector clockwise. Insert the cable through the waterproof connector and wire it into the terminal block.

Note: For Maintained and Non-Maintained wiring please refer to the wiring diagram.

WATERPROOF CONNECTOR

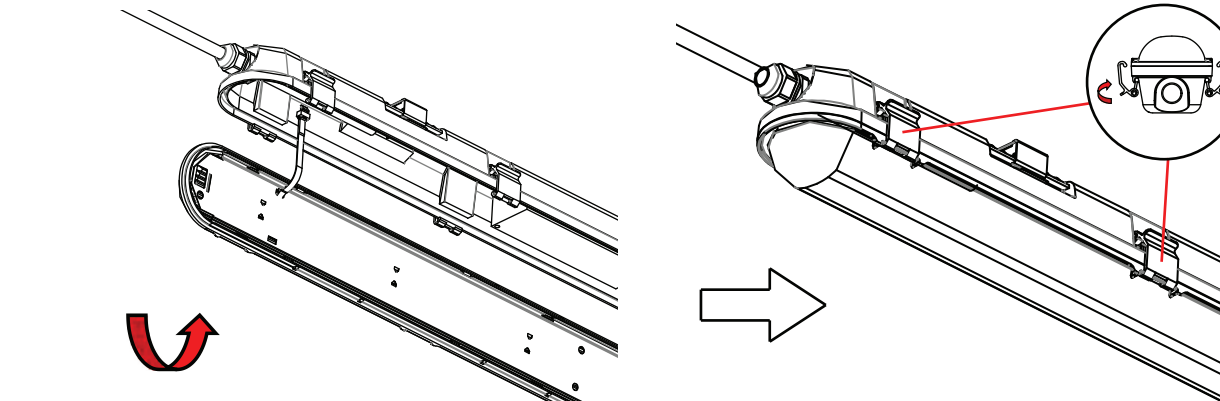

STEP 6: Install the diffuser to the waterproof fitting and close the clips.

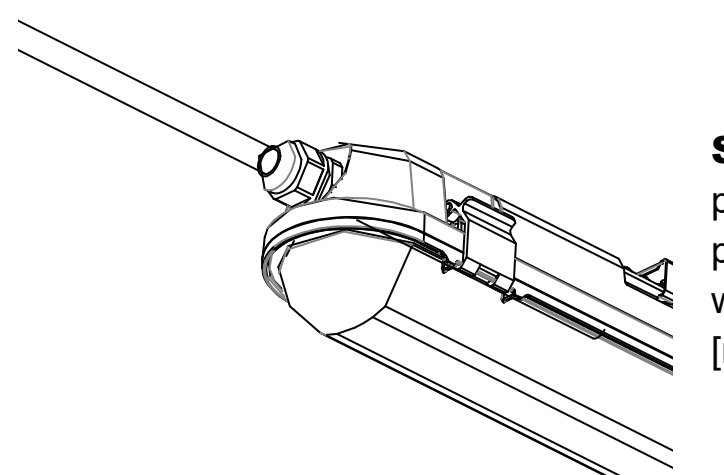

STEP 7: Wire the waterproof fitting to the main power supply. Ensure to use waterproof terminal block [not included].

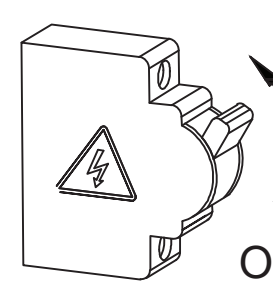

STEP 8: Switch ON the power to test the light.

MULTIPLE (LINKABLE) UNITS INSTALLATION INSTRUCTIONS

Note: Please refer to the model number and max linkable units which can be linked together. Based on the max linkable units select the max waterproof fittings which you would like to connect.

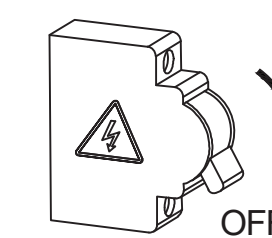

STEP 1: Switch OFF the power before starting the installation.

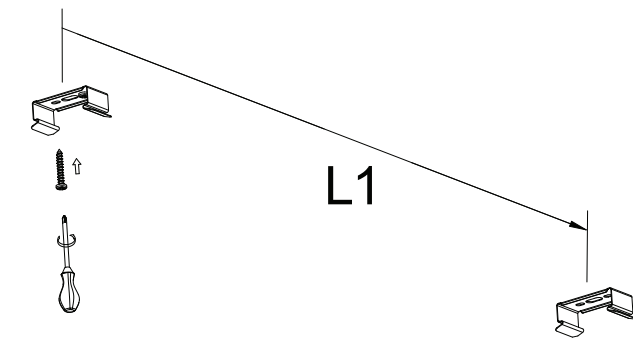

STEP 2: Fix the mounting brackets onto the ceiling using screws and expansion plug (included). Please refer to table 1 for installing the mounting bracket distance points.

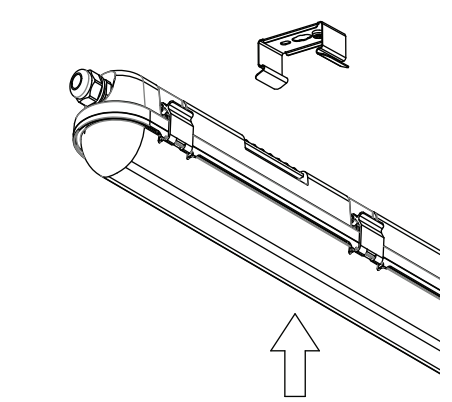

STEP 3: Mount waterproof lamp onto the mounting brackets.

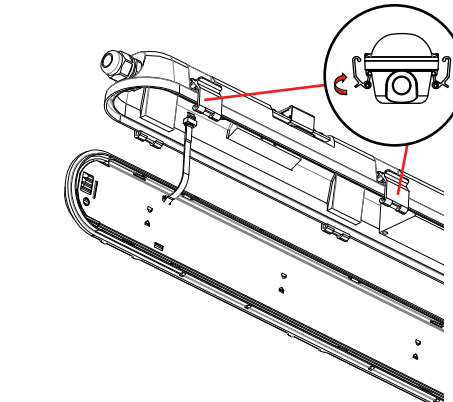

STEP 4: Open the side clips of waterproof fitting and open the diffuser as shown in the diagram.

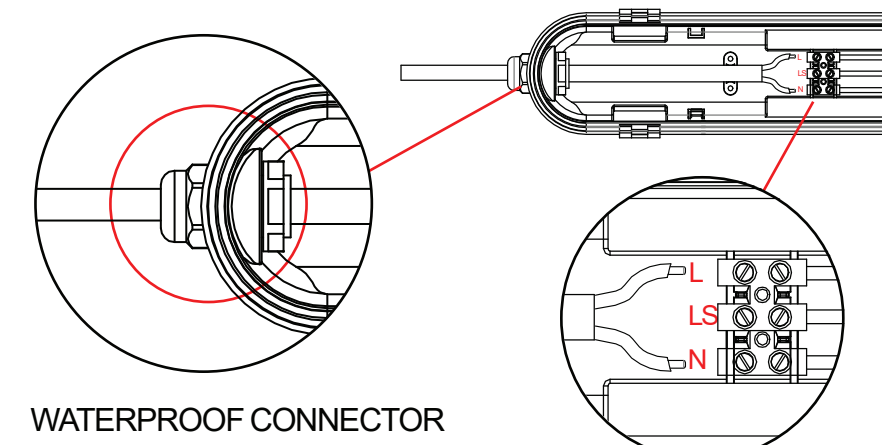

STEP 5: Wiring 1st waterproof fitting from both the ends - Fasten the waterproof connector clockwise from the first end and insert the cable through the waterproof connector and wire into the terminal block from one end.

Note: For Maintained and Non-Maintained wiring please refer to the wiring diagram.

WATERPROOF CONNECTOR

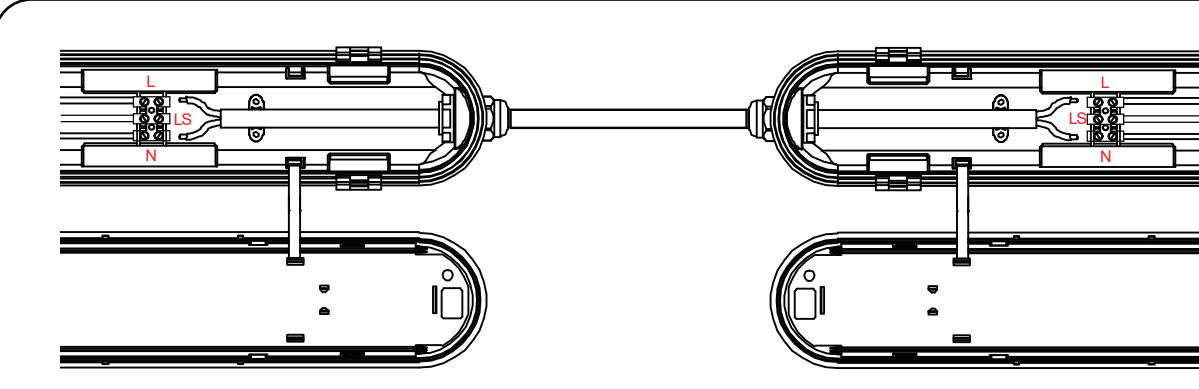

STEP 6: Fasten the waterproof connector from other end of the waterproof fitting and insert the wire into the terminal block. Using the same cable fasten the waterproof connector of the 2nd waterproof fitting and wire into the terminal block.

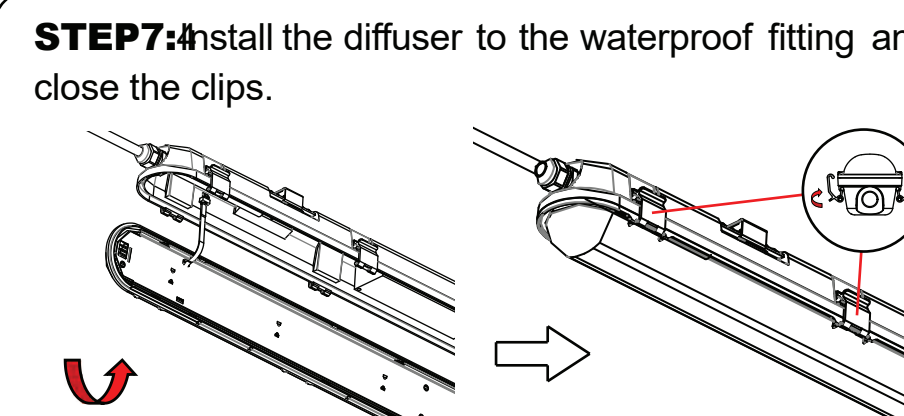

STEP 7: Install the diffuser to the waterproof fitting and close the clips.

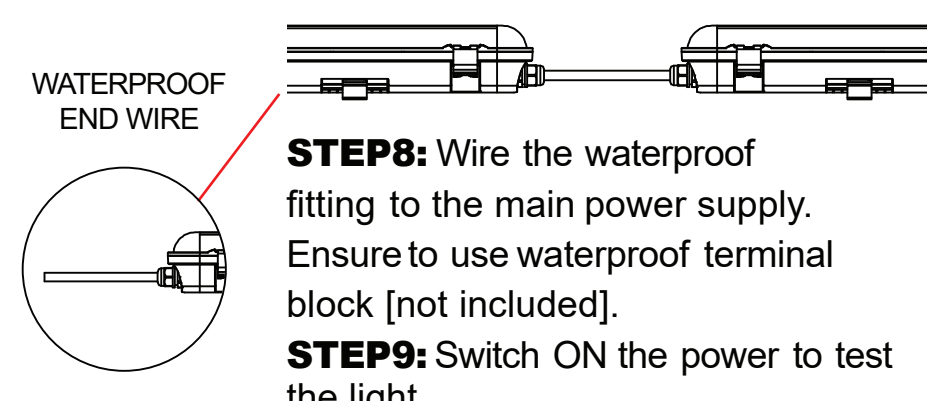

STEP 8: Wire the waterproof fitting to the main power supply. Ensure to use waterproof terminal block [not included].

STEP 9: Switch ON the power to test the light.

WATERPROOF END WIRE